

# Sine Wave Generation Techniques

National Semiconductor  
Application Note 263  
Rereleased May 26, 2009  
October 21, 1999



Producing and manipulating the sine wave function is a common problem encountered by circuit designers. Sine wave circuits pose a significant design challenge because they represent a constantly controlled linear oscillator. Sine wave circuitry is required in a number of diverse areas, including audio testing, calibration equipment, transducer drives, power conditioning and automatic test equipment (ATE). Control of frequency, amplitude or distortion level is often required and all three parameters must be simultaneously controlled in many applications.

A number of techniques utilizing both analog and digital approaches are available for a variety of applications. Each individual circuit approach has inherent strengths and weaknesses which must be matched against any given application (see table).

## Phase Shift Oscillator

A simple inexpensive amplitude stabilized phase shift sine wave oscillator which requires one IC package, three transistors and runs off a single supply appears in *Figure 1*. Q<sub>2</sub>, in combination with the RC network comprises a phase shift

configuration and oscillates at about 12 kHz. The remaining circuitry provides amplitude stability. The high impedance output at Q<sub>2</sub>'s collector is fed to the input of the LM386 via the 10  $\mu$ F-1M series network. The 1M resistor in combination with the internal 50 k $\Omega$  unit in the LM386 divides Q<sub>2</sub>'s output by 20. This is necessary because the LM386 has a fixed gain of 20. In this manner the amplifier functions as a unity gain current buffer which will drive an 8  $\Omega$  load. The positive peaks at the amplifier output are rectified and stored in the 5  $\mu$ F capacitor. This potential is fed to the base of Q<sub>3</sub>. Q<sub>3</sub>'s collector current will vary with the difference between its base and emitter voltages. Since the emitter voltage is fixed by the LM313 1.2V reference, Q<sub>3</sub> performs a comparison function and its collector current modulates Q<sub>1</sub>'s base voltage. Q<sub>1</sub>, an emitter follower, provides servo controlled drive to the Q<sub>2</sub> oscillator. If the emitter of Q<sub>2</sub> is opened up and driven by a control voltage, the amplitude of the circuit output may be varied. The LM386 output will drive 5V (1.75 Vrms) peak-to-peak into 8  $\Omega$  with about 2% distortion. A  $\pm 3$ V power supply variation causes less than  $\pm 0.1$  dB amplitude shift at the output.

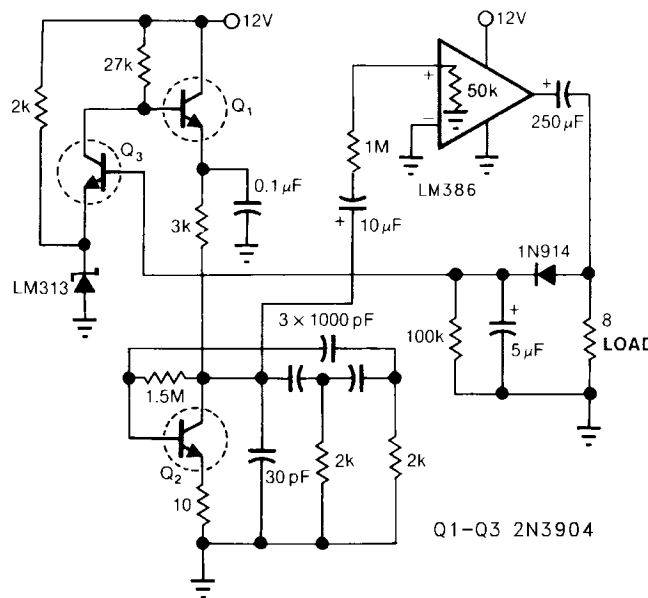

748301

**FIGURE 1. Phase-shift sine wave oscillators combine simplicity with versatility. This 12 kHz design can deliver 5 Vp-p to the 8  $\Omega$  load with about 2% distortion.**

## Sine-Wave-Generation Techniques

Type	Typical Frequency Range	Typical Distortion (%)	Typical Amplitude Stability (%)	Comments
<b>Phase Shift</b>	10 Hz–1 MHz	1–3	3 (Tighter with Servo Control)	Simple, inexpensive technique. Easily amplitude servo controlled. Resistively tunable over 2:1 range with little trouble. Good choice for cost-sensitive, moderate-performance applications. Quick starting and settling.
<b>Wein Bridge</b>	1 Hz–1 MHz	0.01	1	Extremely low distortion. Excellent for high-grade instrumentation and audio applications. Relatively difficult to tune—requires dual variable resistor with good tracking. Take considerable time to settle after a step change in frequency or amplitude.
<b>LC Negative Resistance</b>	1 kHz–10 MHz	1–3	3	Difficult to tune over wide ranges. Higher Q than RC types. Quick starting and easy to operate in high frequency ranges.
<b>Tuning Fork</b>	60 Hz–3 kHz	0.25	0.01	Frequency-stable over wide ranges of temperature and supply voltage. Relatively unaffected by severe shock or vibration. Basically untunable.
<b>Crystal</b>	30 kHz–200 MHz	0.1	1	Highest frequency stability. Only slight (ppm) tuning possible. Fragile.
<b>Triangle-Driven Break-Point Shaper</b>	< 1 Hz–500 kHz	1–2	1	Wide tuning range possible with quick settling to new frequency or amplitude.
<b>Triangle-Driven Logarithmic Shaper</b>	< 1 Hz–500 kHz	0.3	0.25	Wide tuning range possible with quick settling to new frequency or amplitude. Triangle and square wave also available. Excellent choice for general-purpose requirements needing frequency-sweep capability with low-distortion output.
<b>DAC-Driven Logarithmic Shaper</b>	<1 Hz–500 kHz	0.3	0.25	Similar to above but DAC-generated triangle wave generally easier to amplitude-stabilize or vary. Also, DAC can be addressed by counters synchronized to a master system clock.
<b>ROM-Driven DAC</b>	1 Hz–20 MHz	0.1	0.01	Powerful digital technique that yields fast amplitude and frequency slewing with little dynamic error. Chief detriments are requirements for high-speed clock (e.g., 8-bit DAC requires a clock that is 256 × output sine wave frequency) and DAC glitching and settling, which will introduce significant distortion as output frequency increases.

## Low Distortion Oscillation

In many applications the distortion levels of a phase shift oscillator are unacceptable. Very low distortion levels are provided by Wein bridge techniques. In a Wein bridge stable oscillation can only occur if the loop gain is maintained at unity at the oscillation frequency. In *Figure 2a* this is achieved by using the positive temperature coefficient of a small lamp to regulate gain as the output attempts to vary. This is a classic technique and has been used by numerous circuit designers\* to achieve low distortion. The smooth limiting action of the positive temperature coefficient bulb in combination with the near ideal characteristics of the Wein network allow very high performance. The photo of *Figure 3* shows the output of the circuit of *Figure 2a*. The upper trace is the oscillator output. The middle trace is the downward slope of the waveform shown greatly expanded. The slight aberration is due to crossover distortion in the FET-input LF155. This crossover distortion is almost totally responsible for the sum of the measured 0.01% distortion in this oscillator. The output of the distortion analyzer is shown in the bottom trace. In the circuit of *Figure 2b*, an electronic equivalent of the light bulb is used to control loop gain. The zener diode determines the output amplitude and the loop time constant is set by the 1M-2.2  $\mu$ F combination.

The 2N3819 FET, biased by the voltage across the 2.2  $\mu$ F capacitor, is used to control the AC loop gain by shunting the feedback path. This circuit is more complex than *Figure 2a* but offers a way to control the loop time constant while maintaining distortion performance almost as good as in *Figure 2*.

Note: \* Including William Hewlett and David Packard who built a few of these type circuits in a Palo Alto garage about forty years ago.

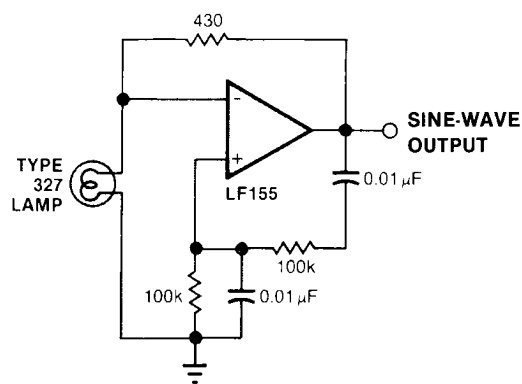

(a)

748302

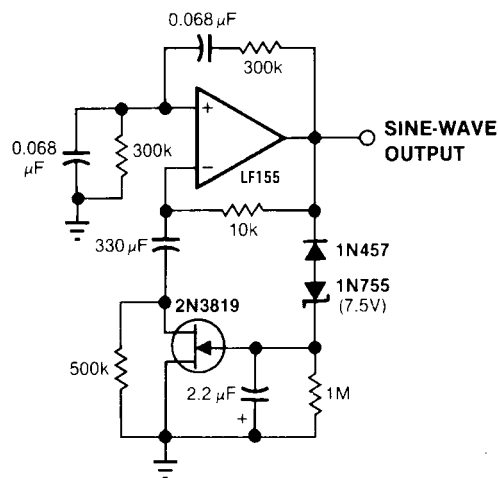

(b)

748303

**FIGURE 2. A basic Wein bridge design (a) employs a lamp's positive temperature coefficient to achieve amplitude stability. A more complex version (b) provides the same feature with the additional advantage of loop time-constant control.**

## High Voltage AC Calibrator

Another dimension in sine wave oscillator design is stable control of amplitude. In this circuit, not only is the amplitude stabilized by servo control but voltage gain is included within the servo loop.

A 100 Vrms output stabilized to 0.025% is achieved by the circuit of *Figure 4*. Although complex in appearance this circuit requires just 3 IC packages. Here, a transformer is used to provide voltage gain within a tightly controlled servo loop. The LM3900 Norton amplifiers comprise a 1 kHz amplitude controllable oscillator. The LH0002 buffer provides low impedance drive to the LS-52 audio transformer. A voltage gain of 100 is achieved by driving the secondary of the transformer and taking the output from the primary. A current-sensitive negative absolute value amplifier composed of two amplifiers of an LF347 quad generates a negative rectified feedback signal. This is compared to the LM329 DC reference at the third LF347 which amplifies the difference at a gain of 100. The 10  $\mu$ F feedback capacitor is used to set the frequency response of the loop. The output of this amplifier controls the amplitude of the LM3900 oscillator thereby closing the loop. As shown the circuit oscillates at 1 kHz with under 0.1% distortion for a 100 Vrms (285 Vp-p) output. If the summing resistors from the LM329 are replaced with a potentiometer the loop is stable for output settings ranging from 3 Vrms to 190 Vrms (542 Vp-p!) with no change in frequency. If the DAC1280 D/A converter shown in dashed lines replaces the LM329 reference, the AC output voltage can be controlled by the digital code input with 3 digit calibrated accuracy.

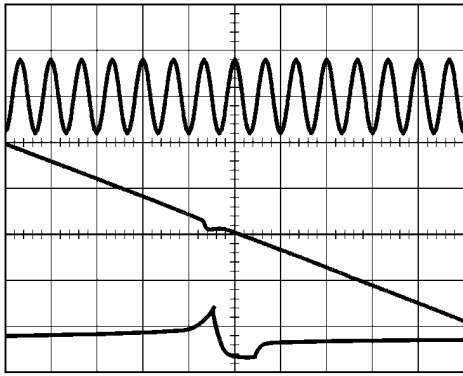

Trace	Vertical	Horizontal
Top	10V/DIV	10 ms/DIV
Middle	1V/DIV	500 ns/DIV
Bottom	0.5V/DIV	500 ns/DIV

748304

**FIGURE 3.** Low-distortion output (top trace) is a Wein bridge oscillator feature. The very low crossover distortion level (middle) results from the LF155's output stage. A distortion analyzer's output signal (bottom) indicates this design's 0.01% distortion level.

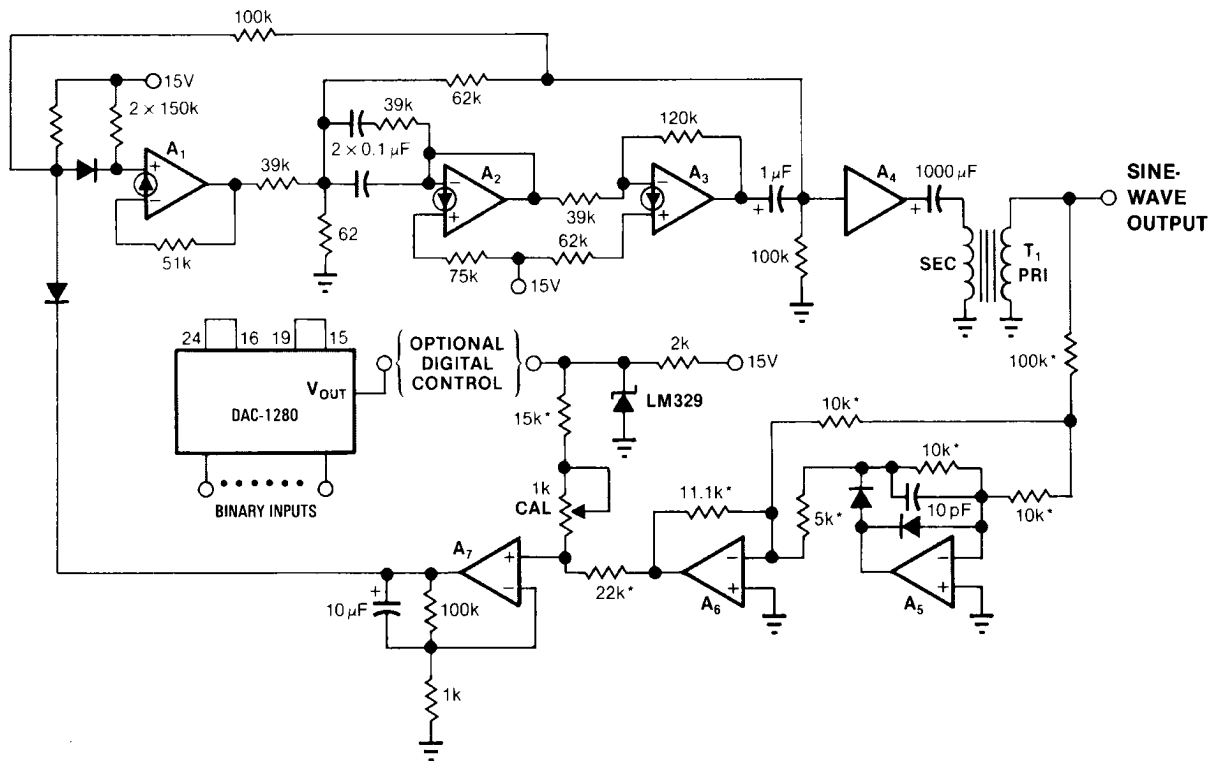

748305

- A1–A3 = ¼ LM3900
- A4 = LH0002
- A5–A7 = ¼ LF347
- T1 = UTC LS-52
- All diodes = 1N914
- \* = low-TC, metal-film types

**FIGURE 4.** Generate high-voltage sine waves using IC-based circuits by driving a transformer in a step-up mode. You can realize digital amplitude control by replacing the LM329 voltage reference with the DAC1287.

## Negative Resistance Oscillator

All of the preceding circuits rely on RC time constants to achieve resonance. LC combinations can also be used and offer good frequency stability, high Q and fast starting.

In *Figure 5* a negative resistance configuration is used to generate the sine wave. The Q1-Q2 pair provides a 15  $\mu$ A current source. Q2's collector current sets Q3's peak collector current. The 300 k $\Omega$  resistor and the Q4-Q5 LM394 matched

pair accomplish a voltage-to-current conversion that decreases Q3's base current when its collector voltage rises. This negative resistance characteristic permits oscillation. The frequency of operation is determined by the LC in the Q3-Q5 collector line. The LF353 FET amplifier provides gain and buffering. Power supply dependence is eliminated by the zener diode and the LF353 unity gain follower. This circuit starts quickly and distortion is inside 1.5%.

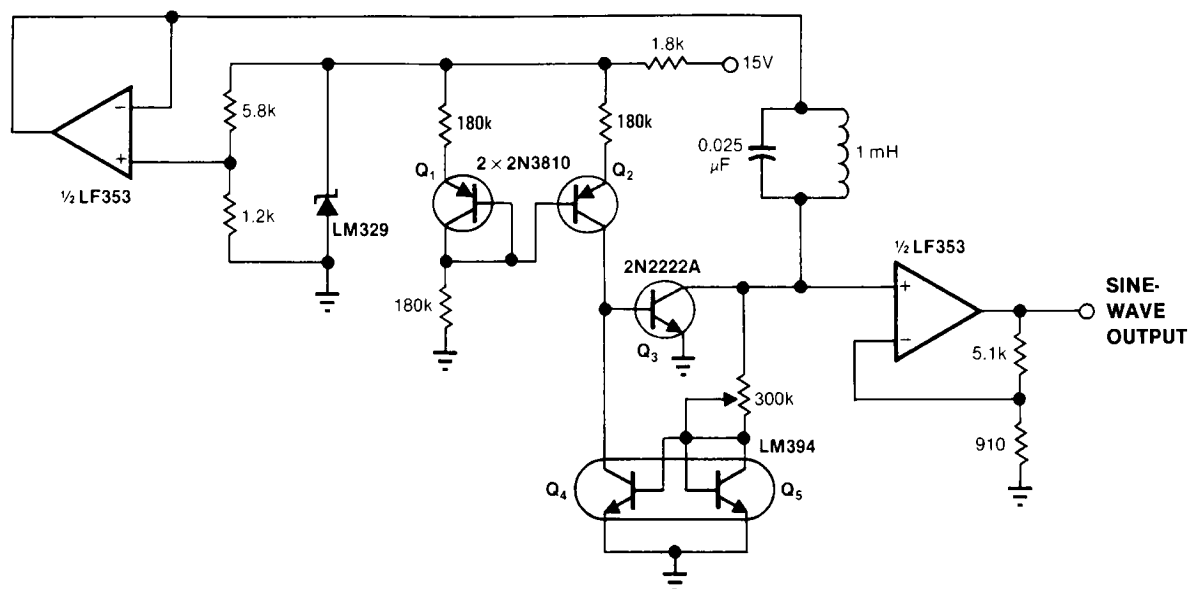

748306

**FIGURE 5.** LC sine wave sources offer high stability and reasonable distortion levels. Transistors Q1 through Q5 implement a negative-resistance amplifier. The LM329, LF353 combination eliminates power-supply dependence.

## Resonant Element Oscillator— Tuning Fork

All of the above oscillators rely on combinations of passive components to achieve resonance at the oscillation frequency. Some circuits utilize inherently resonant elements to achieve very high frequency stability. In *Figure 6* a tuning fork is used in a feedback loop to achieve a stable 1 kHz output. Tuning fork oscillators will generate stable low frequency sine outputs under high mechanical shock conditions which would fracture a quartz crystal.

Because of their excellent frequency stability, small size and low power requirements, they have been used in airborne

applications, remote instrumentation and even watches. The low frequencies achievable with tuning forks are not available from crystals. In *Figure 6*, a 1 kHz fork is used in a feedback loop configuration with Q2, one transistor of an LM3045 array. Q1 provides zener drive to the oscillator circuit. The need for amplitude stabilization is eliminated by allowing the oscillator to go into limit. This is a conventional technique in fork oscillator design. Q3 and Q4 provide edge speed-up and a 5V output for TTL compatibility. Emitter follower Q5 is used to drive an LC filter which provides a sine wave output. *Figure 7*, trace A shows the square wave output while trace B depicts the sine wave output. The 0.7% distortion in the sine wave output is shown in trace C, which is the output of a distortion analyzer.

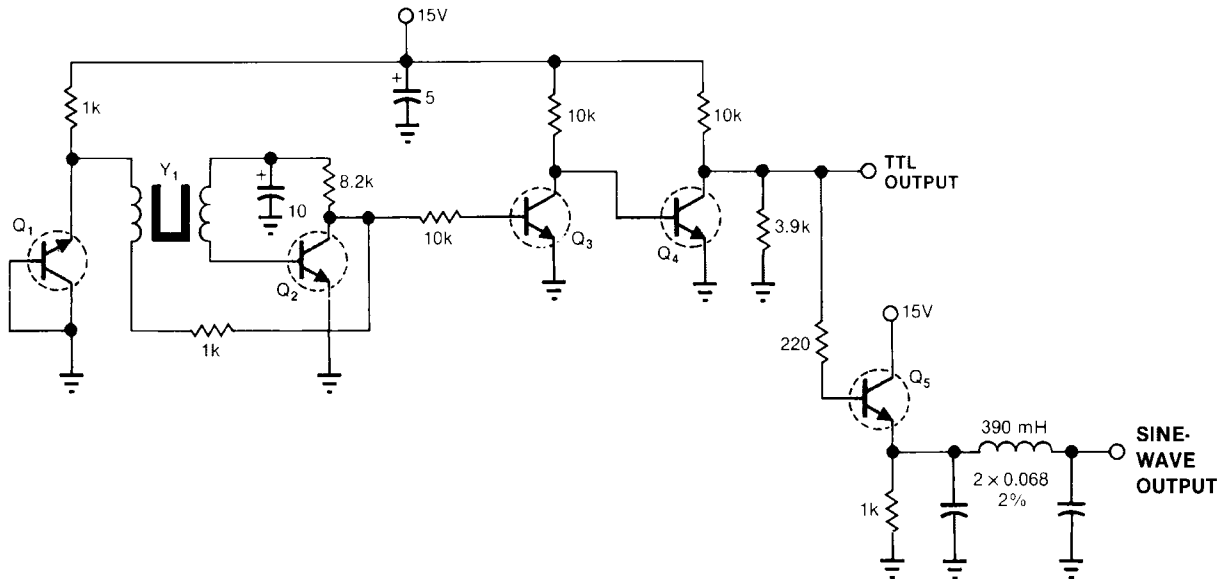

Q1–Q5 = LM3045 array

Y1 = 1 kHz tuning fork, Fork Standards Inc.

All capacitors in  $\mu\text{F}$

748307

**FIGURE 6.** Tuning fork based oscillators don't inherently produce sinusoidal outputs. But when you do use them for this purpose, you achieve maximum stability when the oscillator stage (Q1, Q2) limits. Q3 and Q4 provide a TTL compatible signal, which Q5 then converts to a sine wave.

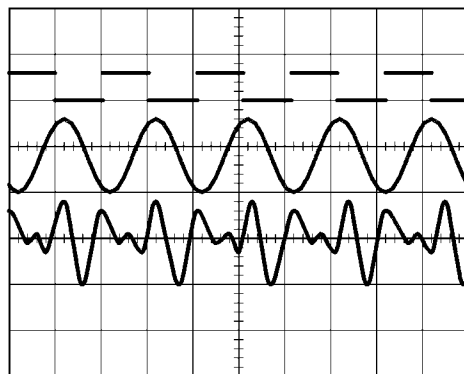

748308

Trace	Vertical	Horizontal
Top	5V/DIV	
Middle	50V/DIV	500 $\mu$ s/DIV
Bottom	0.2V/DIV	

**FIGURE 7.** Various output levels are provided by the tuning fork oscillator shown in *Figure 6*. This design easily produces a TTL compatible signal (top trace) because the oscillator is allowed to limit. Low-pass filtering this square wave generates a sine wave (middle). The oscillator's 0.7% distortion level is indicated (bottom) by an analyzer's output.

## Resonant Element Oscillator— Quartz Crystal

Quartz crystals allow high frequency stability in the face of changing power supply and temperature parameters. *Figure 8a* shows a simple 100 kHz crystal oscillator. This Colpitts class circuit uses a JFET for low loading of the crystal, aiding stability. Regulation will eliminate the small effects ( $\sim 5$  ppm for 20% shift) that supply variation has on this circuit. Shunting the crystal with a small amount of capacitance allows very fine trimming of frequency. Crystals typically drift less than 1 ppm/ $^{\circ}$ C and temperature controlled ovens can be used to eliminate

this term (*Figure 8b*). The RC feedback values will depend upon the thermal time constants of the oven used. The values shown are typical. The temperature of the oven should be set so that it coincides with the crystal's zero temperature coefficient or "turning point" temperature which is manufacturer specified. An alternative to temperature control uses a varactor diode placed across the crystal. The varactor is biased by a temperature dependent voltage from a circuit which could be very similar to *Figure 8b* without the output transistor. As ambient temperature varies the circuit changes the voltage across the varactor, which in turn changes its capacitance. This shift in capacitance trims the oscillator frequency.

## Approximation Methods

All of the preceding circuits are *inherent* sine wave generators. Their normal mode of operation supports and maintains a sinusoidal characteristic. Another class of oscillator is made up of circuits which *approximate* the sine function through a

variety of techniques. This approach is usually more complex but offers increased flexibility in controlling amplitude and frequency of oscillation. The capability of this type of circuit for a digitally controlled interface has markedly increased the popularity of the approach.

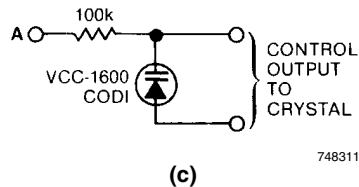
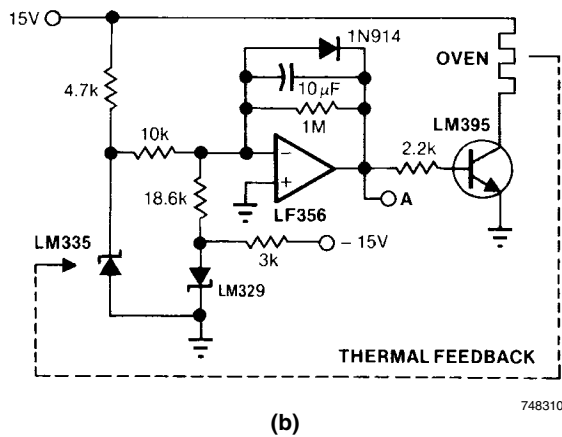
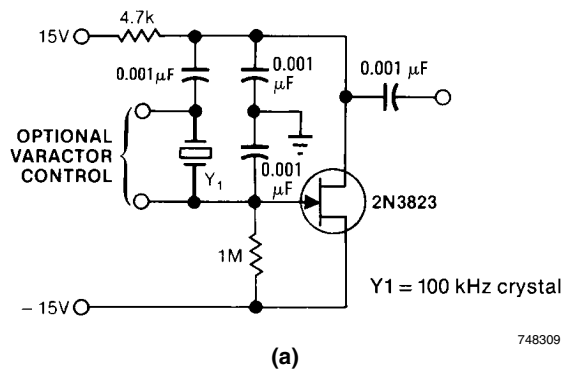

**FIGURE 8.** Stable quartz-crystal oscillators can operate with a single active device (a). You can achieve maximum frequency stability by mounting the oscillator in an oven and using a temperature-controlling circuit (b). A varactor network (c) can also accomplish crystal fine tuning. Here, the varactor replaces the oven and retunes the crystal by changing its load capacitances.



## Sine Approximation—Breakpoint Shaper

Figure 9 diagrams a circuit which will “shape” a 20 Vp-p wave input into a sine wave output. The amplifiers serve to establish stable bias potentials for the diode shaping network. The shaper operates by having individual diodes turn on or off depending upon the amplitude of the input triangle. This changes the gain of the output amplifier and gives the circuit its characteristic non-linear, shaped output response. The values of the resistors associated with the diodes determine the shaped waveform's appearance. Individual diodes in the DC bias circuitry provide first order temperature compensa-

tion for the shaper diodes. Figure 10 shows the circuit's performance. Trace A is the filtered output (note 1000 pF capacitor across the output amplifier). Trace B shows the waveform with no filtering (1000 pF capacitor removed) and trace C is the output of a distortion analyzer. In trace B the breakpoint action is just detectable at the top and bottom of the waveform, but all the breakpoints are clearly identifiable in the distortion analyzer output of trace C. In this circuit, if the amplitude or symmetry of the input triangle wave shifts, the output waveform will degrade badly. Typically, a D/A converter will be used to provide input drive. Distortion in this circuit is less than 1.5% for a filtered output. If no filter is used, this figure rises to about 2.7%.

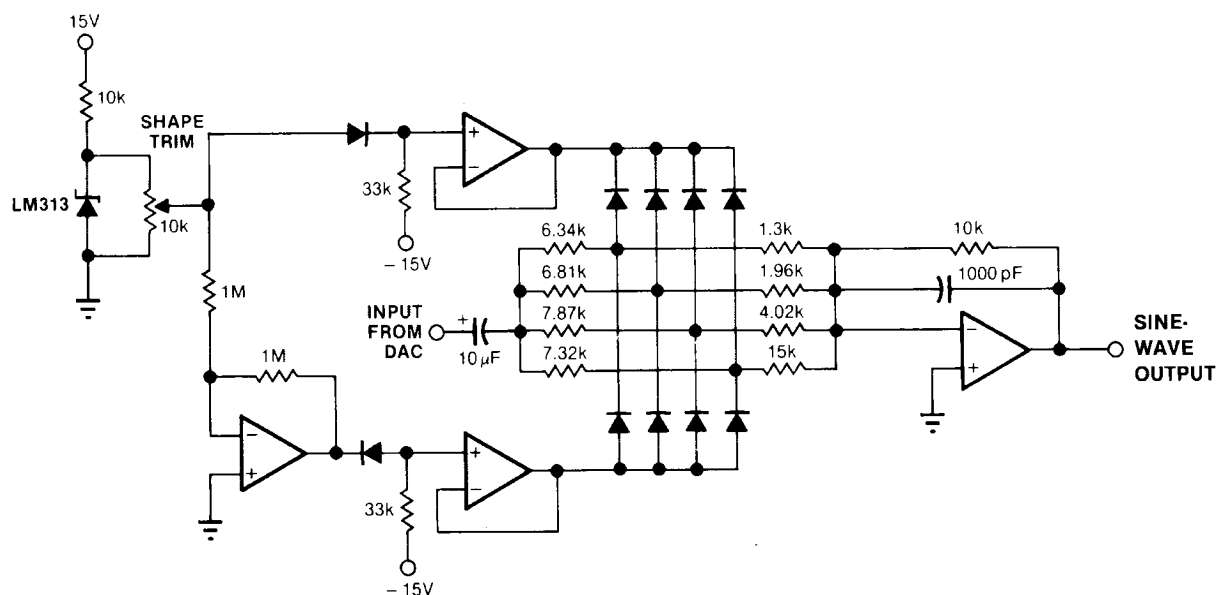

All diodes = 1N4148  
All op amps = ¼ LF347

748312

**FIGURE 9.** Breakpoint shaping networks employ diodes that conduct in direct proportion to an input triangle wave's amplitude. This action changes the output amplifier's gain to produce the sine function.

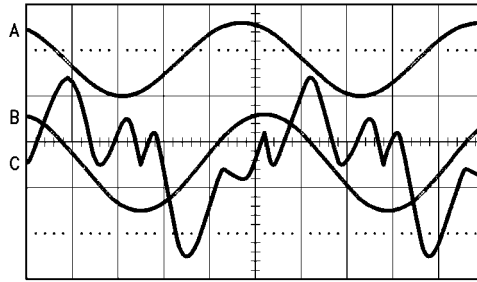

748313

Trace	Vertical	Horizontal
A	5V/DIV	
B	5V/DIV	20 $\mu$ s/DIV
C	0.5V/DIV	

**FIGURE 10.** A clean sine wave results (trace A) when *Figure 9* circuit's output includes a 1000 pF capacitor. When the capacitor isn't used, the diode network's breakpoint action becomes apparent (trace B). The distortion analyzer's output (trace C) clearly shows all the breakpoints.

## Sine Approximation—Logarithmic Shaping

Figure 11 shows a complete sine wave oscillator which may be tuned from 1 Hz to 10 kHz with a single variable resistor. Amplitude stability is inside 0.02%/°C and distortion is 0.35%. In addition, desired frequency shifts occur instantaneously because no control loop time constants are employed. The circuit works by placing an integrator inside the positive feedback loop of a comparator. The LM311 drives symmetrical, temperature-compensated clamp arrangement. The output of the clamp biases the LF356 integrator. The LF356 integrates

this current into a linear ramp at its output. This ramp is summed with the clamp output at the LM311 input. When the ramp voltage nulls out the bound voltage, the comparator changes state and the integrator output reverses. The resultant, repetitive triangle waveform is applied to the sine shaper configuration. The sine shaper utilizes the non-linear, logarithmic relationship between  $V_{be}$  and collector current in transistors to smooth the triangle wave. The LM394 dual transistor is used to generate the actual shaping while the 2N3810 provides current drive. The LF351 allows adjustable, low impedance, output amplitude control. Waveforms of operation are shown in Figure 14.

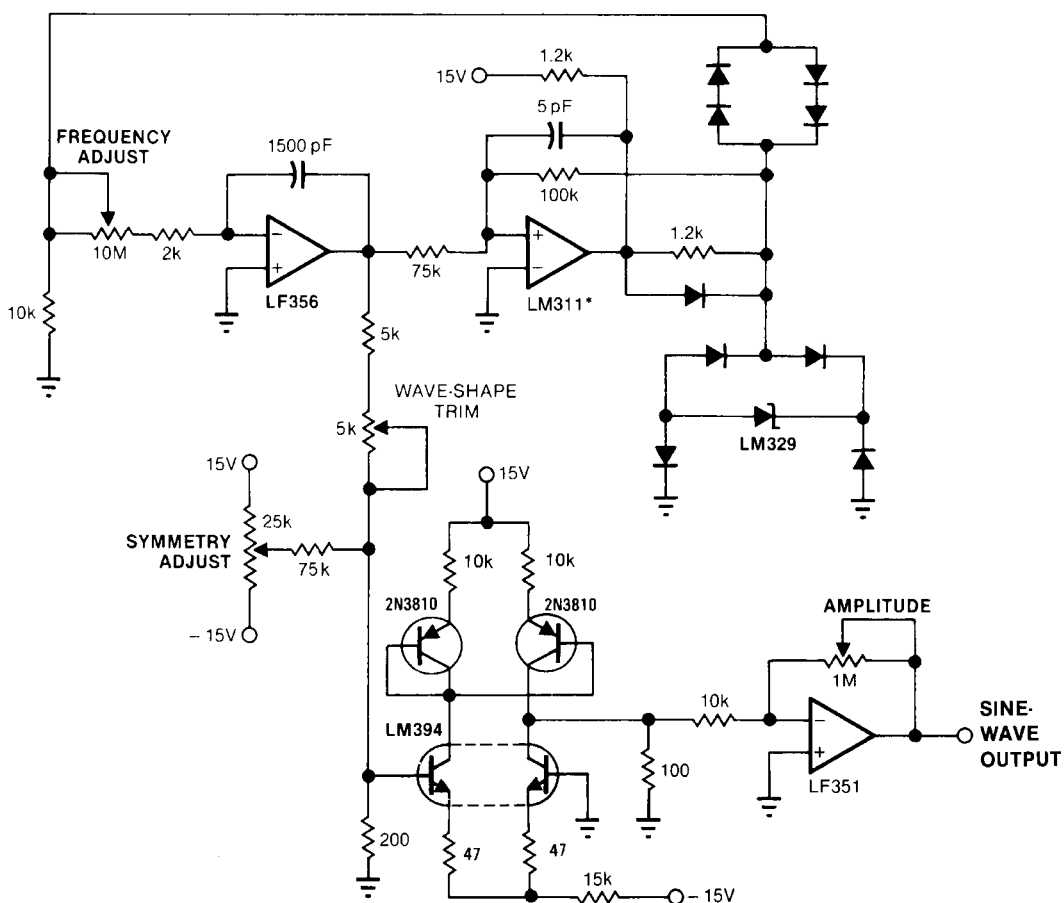

748314

All diodes = 1N4148

Adjust symmetry and wave-  
shape controls for minimum distortion

\* LM311 Ground Pin (Pin 1) at -15V

**FIGURE 11.** Logarithmic shaping schemes produce a sine wave oscillator that you can tune from 1 Hz to 10 kHz with a single control. Additionally, you can shift frequencies rapidly because the circuit contains no control-loop time constants.

## Sine Approximation—Voltage Controlled Sine Oscillator

Figure 12 details a modified but extremely powerful version of Figure 11. Here, the input voltage to the LF356 integrator is furnished from a control voltage input instead of the zener diode bridge. The control input is inverted by the LF351. The two complementary voltages are each gated by the 2N4393 FET switches, which are controlled by the LM311 output. The

frequency of oscillation will now vary in direct proportion to the control input. In addition, because the amplitude of this circuit is controlled by limiting, rather than a servo loop, response to a control step or ramp input is almost instantaneous. For a 0V–10V input the output will run over 1 Hz to 30 kHz with less than 0.4% distortion. In addition, linearity of control voltage vs output frequency will be within 0.25%. Figure 13 shows the response of this circuit (waveform B) to a 10V ramp (waveform A).

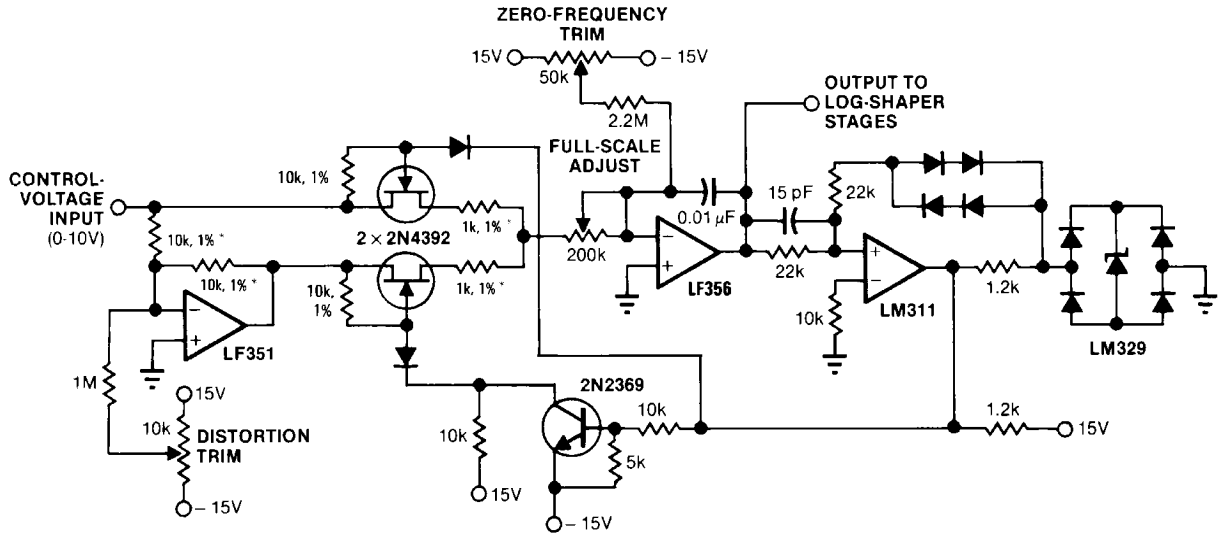

Adjust distortion for minimum at 1 Hz to 10 Hz  
Adjust full-scale for 30 kHz at 10V input  
All diodes = 1N4148  
\* Match to 0.1%

748315

**FIGURE 12.** A voltage-tunable oscillator results when Figure 11's design is modified to include signal-level-controlled feedback. Here, FETs switch the integrator's input so that the resulting summing-junction current is a function of the input control voltage. This scheme realizes a frequency range of 1 Hz to 30 kHz for a 0V to 10V input.

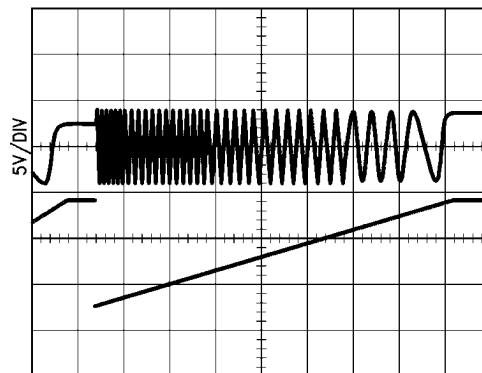

748316

**FIGURE 13.** Rapid frequency sweeping is an inherent feature of Figure 12's voltage-controlled sine wave oscillator. You can sweep this VCO from 1 Hz to 30 kHz with a 10V input signal; the output settles quickly.

## Sine Approximation—Digital Methods

Digital methods may be used to approximate sine wave operation and offer the greatest flexibility at some increase in complexity. *Figure 15* shows a 10-bit IC D/A converter driven from up/down counters to produce an amplitude-stable triangle current into the LF357 FET amplifier. The LF357 is used to drive a shaper circuit of the type shown in *Figure 11*. The output amplitude of the sine wave is stable and the frequency is solely dependent on the clock used to drive the counters. If the clock is crystal controlled, the output sine wave will reflect the high frequency stability of the crystal. In this example, 10 binary bits are used to drive the DAC so the output frequency will be 1/1024 of the clock frequency. If a sine coded read-only-memory is placed between the counter outputs and

the DAC, the sine shaper may be eliminated and the sine wave output taken directly from the LF357. This constitutes an extremely powerful digital technique for generating sine waves. The amplitude may be voltage controlled by driving the reference terminal of the DAC. The frequency is again established by the clock speed used and both may be varied at high rates of speed without introducing significant lag or distortion. Distortion is low and is related to the number of bits of resolution used. At the 8-bit level only 0.5% distortion is seen (waveforms, *Figure 16*; graph, *Figure 17*) and filtering will drop this below 0.1%. In the photo of *Figure 16* the ROM directed steps are clearly visible in the sine waveform and the DAC levels and glitching show up in the distortion analyzer output. Filtering at the output amplifier does an effective job of reducing distortion by taking out these high frequency components.

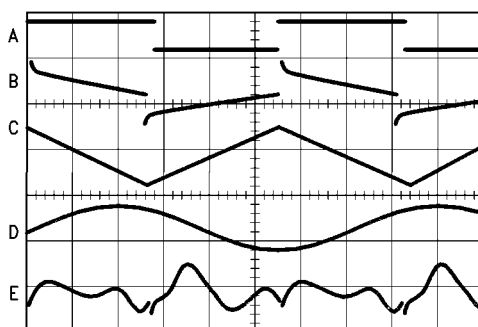

748317

Trace	Vertical	Horizontal
A	20V/DIV	
B	20V/DIV	20 $\mu$ s/DIV
C	10V/DIV	
D	10V/DIV	
E	0.5V/DIV	

**FIGURE 14.** Logarithmic shapers can utilize a variety of circuit waveforms. The input to the LF356 integrator (*Figure 11*) appears here as trace A. The LM311's input (trace B) is the summed result of the integrator's triangle output (C) and the LM329's clamped waveform. After passing through the 2N3810/LM394 shaper stage, the resulting sine wave is amplified by the LF351 (D). A distortion analyzer's output (E) represents a 0.35% total harmonic distortion.

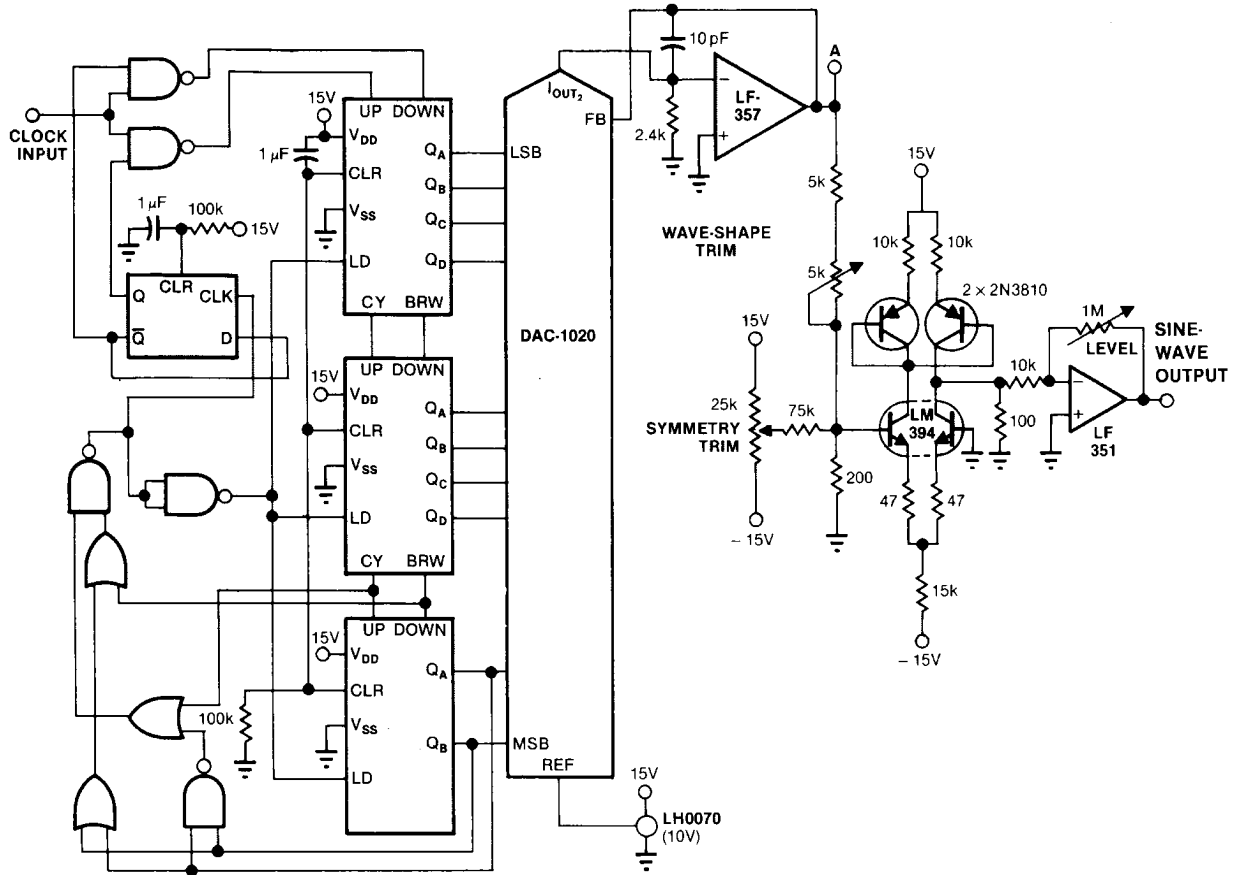

MM74C00 = NAND  
 MM74C32 = OR  
 MM74C74 = D flip-flop  
 MM74193 = counters

748318

**FIGURE 15.** Digital techniques produce triangular waveforms that methods employed in *Figure 11* can then easily convert to sine waves. This digital approach divides the input clock frequency by 1024 and uses the resultant 10 bits to drive a DAC. The DAC's triangular output—amplified by the LF357—drives the log shaper stage. You could also eliminate the log shaper and place a sine-coded ROM between the counters' outputs and the DAC, then recover the sine wave at point A.

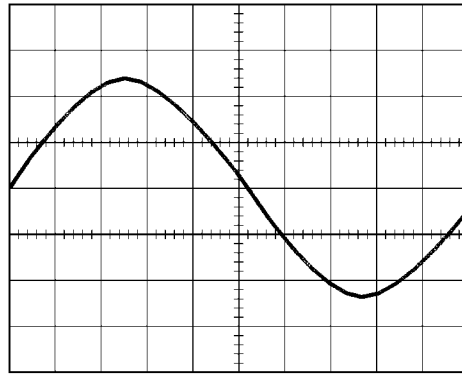

748319

Trace	Vertical	Horizontal
Sine Wave	1V/DIV	200 $\mu$ s/DIV
Analyzer	0.2V/DIV	

**FIGURE 16.** An 8-bit sine coded ROM version of *Figure 15's* circuit produces a distortion level less than 0.5%. Filtering the sine output—shown here with a distortion analyzer's trace—can reduce the distortion to below 0.1%.

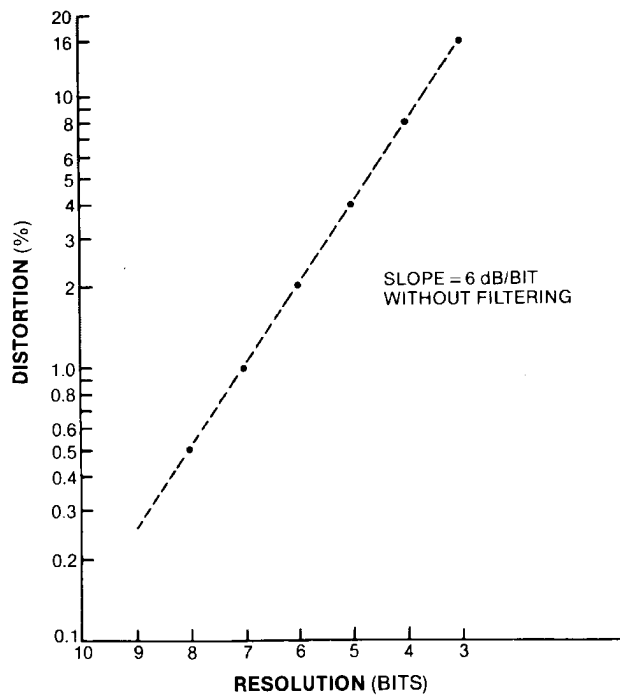

748320

**FIGURE 17.** Distortion levels decrease with increasing digital word length. Although additional filtering can considerably improve the distortion levels (to 0.1% from 0.5% for the 8-bit case), you're better off using a long digital word.

## Notes

For more National Semiconductor product information and proven design tools, visit the following Web sites at:

Products		Design Support	
Amplifiers	<a href="http://www.national.com/amplifiers">www.national.com/amplifiers</a>	WEBENCH® Tools	<a href="http://www.national.com/webench">www.national.com/webench</a>
Audio	<a href="http://www.national.com/audio">www.national.com/audio</a>	App Notes	<a href="http://www.national.com/appnotes">www.national.com/appnotes</a>
Clock and Timing	<a href="http://www.national.com/timing">www.national.com/timing</a>	Reference Designs	<a href="http://www.national.com/refdesigns">www.national.com/refdesigns</a>
Data Converters	<a href="http://www.national.com/adc">www.national.com/adc</a>	Samples	<a href="http://www.national.com/samples">www.national.com/samples</a>
Interface	<a href="http://www.national.com/interface">www.national.com/interface</a>	Eval Boards	<a href="http://www.national.com/evalboards">www.national.com/evalboards</a>
LVDS	<a href="http://www.national.com/lvds">www.national.com/lvds</a>	Packaging	<a href="http://www.national.com/packaging">www.national.com/packaging</a>
Power Management	<a href="http://www.national.com/power">www.national.com/power</a>	Green Compliance	<a href="http://www.national.com/quality/green">www.national.com/quality/green</a>
Switching Regulators	<a href="http://www.national.com/switchers">www.national.com/switchers</a>	Distributors	<a href="http://www.national.com/contacts">www.national.com/contacts</a>
LDOs	<a href="http://www.national.com/ldo">www.national.com/ldo</a>	Quality and Reliability	<a href="http://www.national.com/quality">www.national.com/quality</a>
LED Lighting	<a href="http://www.national.com/led">www.national.com/led</a>	Feedback/Support	<a href="http://www.national.com/feedback">www.national.com/feedback</a>
Voltage Reference	<a href="http://www.national.com/vref">www.national.com/vref</a>	Design Made Easy	<a href="http://www.national.com/easy">www.national.com/easy</a>
PowerWise® Solutions	<a href="http://www.national.com/powerwise">www.national.com/powerwise</a>	Solutions	<a href="http://www.national.com/solutions">www.national.com/solutions</a>
Serial Digital Interface (SDI)	<a href="http://www.national.com/sdi">www.national.com/sdi</a>	Mil/Aero	<a href="http://www.national.com/milaero">www.national.com/milaero</a>
Temperature Sensors	<a href="http://www.national.com/tempensors">www.national.com/tempensors</a>	SolarMagic™	<a href="http://www.national.com/solarmagic">www.national.com/solarmagic</a>
Wireless (PLL/VCO)	<a href="http://www.national.com/wireless">www.national.com/wireless</a>	PowerWise® Design University	<a href="http://www.national.com/training">www.national.com/training</a>

THE CONTENTS OF THIS DOCUMENT ARE PROVIDED IN CONNECTION WITH NATIONAL SEMICONDUCTOR CORPORATION ("NATIONAL") PRODUCTS. NATIONAL MAKES NO REPRESENTATIONS OR WARRANTIES WITH RESPECT TO THE ACCURACY OR COMPLETENESS OF THE CONTENTS OF THIS PUBLICATION AND RESERVES THE RIGHT TO MAKE CHANGES TO SPECIFICATIONS AND PRODUCT DESCRIPTIONS AT ANY TIME WITHOUT NOTICE. NO LICENSE, WHETHER EXPRESS, IMPLIED, ARISING BY ESTOPPEL OR OTHERWISE, TO ANY INTELLECTUAL PROPERTY RIGHTS IS GRANTED BY THIS DOCUMENT.

TESTING AND OTHER QUALITY CONTROLS ARE USED TO THE EXTENT NATIONAL DEEMS NECESSARY TO SUPPORT NATIONAL'S PRODUCT WARRANTY. EXCEPT WHERE MANDATED BY GOVERNMENT REQUIREMENTS, TESTING OF ALL PARAMETERS OF EACH PRODUCT IS NOT NECESSARILY PERFORMED. NATIONAL ASSUMES NO LIABILITY FOR APPLICATIONS ASSISTANCE OR BUYER PRODUCT DESIGN. BUYERS ARE RESPONSIBLE FOR THEIR PRODUCTS AND APPLICATIONS USING NATIONAL COMPONENTS. PRIOR TO USING OR DISTRIBUTING ANY PRODUCTS THAT INCLUDE NATIONAL COMPONENTS, BUYERS SHOULD PROVIDE ADEQUATE DESIGN, TESTING AND OPERATING SAFEGUARDS.

EXCEPT AS PROVIDED IN NATIONAL'S TERMS AND CONDITIONS OF SALE FOR SUCH PRODUCTS, NATIONAL ASSUMES NO LIABILITY WHATSOEVER, AND NATIONAL DISCLAIMS ANY EXPRESS OR IMPLIED WARRANTY RELATING TO THE SALE AND/OR USE OF NATIONAL PRODUCTS INCLUDING LIABILITY OR WARRANTIES RELATING TO FITNESS FOR A PARTICULAR PURPOSE, MERCHANTABILITY, OR INFRINGEMENT OF ANY PATENT, COPYRIGHT OR OTHER INTELLECTUAL PROPERTY RIGHT.

#### LIFE SUPPORT POLICY

**NATIONAL'S PRODUCTS ARE NOT AUTHORIZED FOR USE AS CRITICAL COMPONENTS IN LIFE SUPPORT DEVICES OR SYSTEMS WITHOUT THE EXPRESS PRIOR WRITTEN APPROVAL OF THE CHIEF EXECUTIVE OFFICER AND GENERAL COUNSEL OF NATIONAL SEMICONDUCTOR CORPORATION.** As used herein:

Life support devices or systems are devices which (a) are intended for surgical implant into the body, or (b) support or sustain life and whose failure to perform when properly used in accordance with instructions for use provided in the labeling can be reasonably expected to result in a significant injury to the user. A critical component is any component in a life support device or system whose failure to perform can be reasonably expected to cause the failure of the life support device or system or to affect its safety or effectiveness.

National Semiconductor and the National Semiconductor logo are registered trademarks of National Semiconductor Corporation. All other brand or product names may be trademarks or registered trademarks of their respective holders.

Copyright© 2009 National Semiconductor Corporation

For the most current product information visit us at [www.national.com](http://www.national.com)



**National Semiconductor  
Americas Technical  
Support Center**  
Email: [support@nsc.com](mailto:support@nsc.com)  
Tel: 1-800-272-9959

**National Semiconductor Europe  
Technical Support Center**  
Email: [europe.support@nsc.com](mailto:europe.support@nsc.com)

**National Semiconductor Asia  
Pacific Technical Support Center**  
Email: [ap.support@nsc.com](mailto:ap.support@nsc.com)

**National Semiconductor Japan  
Technical Support Center**  
Email: [jpn.feedback@nsc.com](mailto:jpn.feedback@nsc.com)